

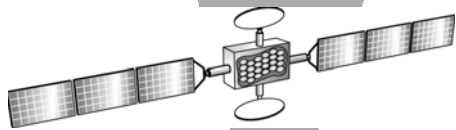

Protection Switch System Operating Manual



ANASAT[®] - PS



Rev 03



ANASAT[®]-PS

Protection Switch System Operating Manual



You have just received an AnaSat[®]-Protection Switch System, a *cost-effective* product with no compromise on *quality* or *reliability*. This product should provide tireless performance in any reasonable operating environment.

We, at **ANACOM**, have taken great care to provide a convenient, easy-to-use product in a small outdoor package. The Protection Switch consist of a Protection Controller outdoor box, and WR-229 and WR-137 waveguide switches for C-Band applications, or a pair of WR-75 waveguide switches for Ku-Band applications. Should a situation arise beyond the operator's control, just give us a telephone call. Many situations can be diagnosed and solved by **ANACOM**'s trained customer-service personnel over the phone.

If you have any questions, require technical assistance or training please call **ANACOM** directly at (408) 519-2062 or FAX to us at (408) 519-2063. You can also send e-mail to techsupport@anacominc.com and one of our engineers will contact you.

ANACOM, INC.

**1996 Lundy Ave.
San Jose, CA 95131
Tel: (408) 519-2062
Fax: (408) 519-2063**

© 2009 AnaCom, Inc. All rights reserved. The information furnished by AnaCom, Incorporated, in this publication is believed to be accurate and reliable. However, no responsibility is assumed by AnaCom for its use, nor any infringements of patents or other rights of third parties resulting from its use. No license is granted by implication or otherwise under any patent or patent right of AnaCom, Inc. AnaCom reserves the right to change circuitry and specifications at any time without prior notice.

The following terms are trademarks of their respective holders:

AnaSat, AnaCom, Inc.

Polyswitch

Teflon

Duroid

VT52, VT100 Digital Equipment Corp.

INTELSAT

Operating Manual

for the

ANASAT[®]-PS

Protection Switch System

Table of Contents

| <u>Subject</u> | <u>Page</u> |
|---|--------------------|
| Section 1. Product Introduction and Specifications | 1-1 |
| Typical Operating Parameters | 1-3 |
| Section 2. Installation | 2-1 |
| Unpacking | 2-1 |
| Packing List | 2-1 |
| Safety Precautions | 2-1 |
| Site Considerations | 2-2 |
| Protection Switch Mounting RF Considerations | 2-2 |
| Protection Switch Mounting DC Considerations | 2-2 |
| Physical Mounting Considerations | 2-3 |
| Cable and Waveguide Connections | 2-3 |
| Water Resistance Wrap | 2-5 |
| Section 3. Operation | 3-1 |
| Preliminary Steps | 3-1 |
| Manual Operation | 3-1 |
| M & C Operation | 3-2 |

| <u>Subject</u> | <u>Page</u> |
|--|--------------------|
| Section 4. Theory of Operation | 4-1 |
| Switch Logic | 4-1 |
| Receive Signal Switching | 4-1 |
| Transmit Signal Switching | 4-2 |
| Switch Power Control | 4-3 |
| Monitor & Control | 4-3 |
| | |
| Section 5. Serial Port Operation | 5-1 |
| Software Applications Considerations | 5-1 |
| RS-232 Data Terminal Connection | 5-2 |
| RS-485 Data Terminal Single Connection | 5-2 |
| RS-485 Data Terminal Multiple Connection | 5-3 |
| RS-485 Data Terminal Translator | 5-4 |
| | |
| Section 6. Maintenance | 6-1 |
| Built-In Test Equipment | 6-1 |
| Controllable Functions from the Terminal | 6-1 |
| Limited Warranty | 6-1 |
| | |
| Appendices | |
| Appendix A. M & C Command Set | A-1 |
| Appendix B. Alarm List | B-1 |
| Appendix C. Connector Wiring | C-1 |
| Appendix D. Drawings and Diagrams | D-1 |
| Appendix E. AnaSat Hand-Held Terminal Guide | E-1 |

Section 1. Introduction



Figure 1-1 The ANASAT®-PS Protection Switch

The ANASAT®-PS is a VSAT protection system designed for continuous outdoor duty in all types of environments. Ideally suited for SCPC, MCPC, and DAMA applications where high reliability requirements dictate the use of protected RF equipment.

The Protection Switch, TX Only (32314) provides complete 1 for 1 protection for TX only applications. Full TX and RX protection is provided with the model 30712. This works exactly the same way as the TX Only unit, but includes an independent RX switch function as well. This means that both an RX and a TX fault (double fault) can occur at the same time and the station can still operate normally.



Figure 1-2 The ANASAT®-PS Protection Switch TX only

This manual will normally refer to the TX/RX Protection Switch version unless specifically noted. Both units work exactly the same way.

The ANASAT®-PS VSAT protection unit integrates all necessary functions, including complete switch control logic, display indicators, microprocessor, and two independent serial ports into a single, small outdoor package. Only the actual waveguide relays are mounted separately. There is no need for any indoor control box or power.

Designed to interface with any of the ANASAT C or Ku VSAT transceivers, ELSAT block up converters, and ANASAT SSPA units, the Protection Switch can be used in a wide variety of communication network situations where redundant radio equipment is required.

The earth stations may be configured with the optional Station Management System (SMS), tied to a PC, where you can monitor and control all local transceivers and other network-compatible equipment including the Protection Switch.

The ANASAT®-PS Protection Switch splits the modulator's output to feed both A and B transceivers in parallel. This TX IF splitter function works for IF signals from 50 MHz through L band. For applications where the TX Only unit is protecting a pair of SSPA amplifiers, an external microwave splitter must be used to drive the two SSPA units.

The received IF signal from each transceiver is fed to the Protection Switch where a high quality RF relay is used to select either the A or the B transceiver. The selected signal is sent to the modem equipment.

The transmit RF signal from each transceiver is sent to a waveguide relay which can be a type-N, WR-137, or WR-75. That relay is directly controlled by the Protection Switch via a 6 conductor cable. The relay is constantly monitored to insure that the relay is locked to the selected transceiver. The TX relay can be mounted in any convenient location. It

is usually positioned to minimize waveguide (or coax) lengths.

The receive RF signal from the antenna feed system is switched to either transceiver A or transceiver B with an RX waveguide relay. This relay can be either a WR-229 for C band, or a WR-75 for Ku band operation. In order to minimize signal losses, this relay is normally mounted directly on the feed port. The relay switches the receive signal from the antenna to either the A side LNC or the B side LNC. Each LNC is then connected to its own transceiver via coax cable. This arrangement provides the maximum amount of equipment protection without loss of system performance.

The protection switch system can also be used with a pair of LNBS in place of the LNCs. In this case, the Protection Switch monitors the health of the LNBS by measuring DC current consumption but does NOT provide LNB power. That power must come from the user through the TX IF cable and it must be sufficient to power two LNBS.

The RX relay is controlled directly from the Protection Switch unit via a 6 conductor cable. The relay is constantly monitored to insure that the relay is locked to the selected transceiver.

Power for the Protection Switch system comes directly from both transceivers. No other power source is needed. Even if one transceiver suffers a power loss or is shut down externally, the remaining transceiver can supply enough power to the Protection Switch for it to operate normally.

In the case where a TX/RX Protection Switch system is used to interface with two ELSAT BUCs and two LNBS, the LNBS are powered from the modem, via the Protection Switch Control box. There must be sufficient power for both LNBS, or the system may fail.

Typical Operating Parameters

RF ELECTRICAL SPECIFICATIONS

A. TRANSMIT RF SWITCH

- | | | |
|-----|-------------------------------------|------------------------------------|
| (1) | Transmit RF Waveguide Relay Options | |
| | a) WR-137 | C-Band |
| | b) WR-75 | Ku-Band |
| | c) Type N Connection Option | C-Band |
| (2) | Maximum Power Level | 1,000 Watts |
| (3) | Switch Time | 2S maximum |
| (4) | Off-line Load VSWR | < 1.5:1 |
| (5) | Off-line Load Power | Options for 20 through 1,000 Watts |

B. TRANSMIT IF SPLITTER

- | | | |
|-----|-----------------|----------------------------|
| (1) | Connector Type | Type N |
| (2) | Frequency Range | 50 to 2000 MHz |
| (3) | Impedance | 50 Ohms (75 Ohms optional) |
| (4) | Insertion Loss | 7 dB maximum |
| (5) | Switch time | 0 S (splitter) |

C. RECEIVER RF SWITCH

- | | | |
|-----|------------------------------------|------------|
| (1) | Receive RF Waveguide Relay Options | |
| | a) WR-229 | C-Band |
| | b) WR-75 | Ku-Band |
| (2) | Switch Time | 2S maximum |
| (3) | Off-line Load VSWR | < 1.5:1 |

D. RECEIVE IF SWITCH

- | | | |
|-----|-----------------|----------------------------|
| (1) | Connector Type | Type N |
| (2) | Frequency Range | 50 to 2000 MHz |
| (3) | Impedance | 50 Ohms (75 Ohms optional) |
| (4) | Insertion Loss | 1 dB maximum |
| (5) | Switch Time | 2S maximum |

RF ELECTRICAL SPECIFICATIONS, (con't.)
E. POWER REQUIREMENTS

| | | |
|-----|-----------------------------------|---------------------------|
| (1) | Voltage | +13 VDC |
| (2) | Current, nominal during switching | 0.1 Amps 5 Amps peak |
| (3) | Source | Transceiver M&C connector |

MECHANICAL SPECIFICATIONS
A. WEIGHT

| | | |
|-----|-------------------------|-------------------------|
| (1) | Protection Switch unit | 3 lbs (1.8 kg) max. |
| (2) | RF Relays | |
| | WR-229 waveguide switch | 6 lbs (2.73 kg) max. |
| | WR-137 waveguide switch | 2.5 lbs (1.14 kg) max. |
| | WR-75 waveguide switch | 1.5 lbs (0.68 kg) max.. |
| | Type N switch (option) | 1.10 lbs (0.49 kg) max. |

B. SIZE

| | | |
|-----|---------------------------------|--|
| (1) | Protection Switch unit | 8.5" x 9.5" x 4.0" (215.9 x 241.3 x 101.6 mm) |
| (2) | RF Relays | |
| | WR-229 waveguide switch | 3.45" x 3.45" x 7.73" (87.6 x 87.6 x 196.3 mm) |
| | WR-137 waveguide switch | 2.25" x 2.25" x 5.12" (57.2 x 57.2 x 130 mm) |
| | WR-75 waveguide switch (option) | 2.20" x 2.20" x 4.07" (55.8 x 55.8 x 103.4 mm) |
| | Type N switch (option) | 2.00" x 2.00" x 3.05" (50.8 x 50.8 x 77.5 mm) |

C. SURFACE FINISH

Painted Surface

(a) Color (per FED-STD-595A, Spec. # 25630) Light Gray

(b) Final Coating: Powder

Unpainted Surfaces: Chem. Film per MIL-C-5541, Class 3

ENVIRONMENTAL SPECIFICATIONS

| | | |
|----|--------------------------------|-------------------------|
| A. | AMBIENT TEMPERATURE CONDITIONS | |
| | (1) Operating | -40 to +50°C |
| | (2) Storage | -60 to +75°C |
| B. | ALTITUDE | 15000' ASL max. (4560m) |
| C. | RAIN | 20" / hour (508mm/hr) |
| D. | WIND | 150 MPH (250km/hr) |
| E. | VIBRATION | |
| | (1) Operating | 1.0 G random |
| | (2) Survival | 2.5 G maximum random |
| F. | SHOCK | |
| | (1) Operating | 10G |
| | (2) Survival | 40G max. |

NOTE: Specifications subject to change without notice.

Section 2. Installation

The ANASAT®-PS Protection Switch system consists of the Protection Switch box, one TX Waveguide (or possibly coax) Relay, and one RX Waveguide Relay as needed.

This chapter contains the general requirements for installing the Protection Switch and associated Relays on the antenna and making the cable and waveguide connections. Specific mounting methods may vary considerably depending upon particular antenna and site characteristics. Refer to the antenna manufacturer's instructions for more detailed instructions.

ANASAT®-Protection Switch control box is designed for installation and setup without removing the cover. The control box may be completely initialized for normal operation using a Hand Held ASCII terminal or a local computer.



Removal of any cover may jeopardize the weather seal which may cause problems later.

Unpacking

Check to make sure that the Control box and the Waveguide Relays have not suffered any damage in shipment. Compare contents of the crate to ensure items received match those listed on the packing slip. Retain all shipping containers for future use.

Tools and Test Equipment

Have on-hand a standard electrician's tool kit and any tools listed in your antenna installation instructions.

ANASAT®-PS Packing List

- Protection Switch Box
- TX Waveguide (or coax) Relay
- RX Waveguide Relay
- This Manual
- Quick Start Guide

Note: A cable kit containing several possible cables may, or may not be included in this shipment.

Table 2-1. ANASAT®-PS Packing List

Safety Precautions

General



Observe normal safety precautions when operating this equipment.

Ensure the Waveguide Relays and the Control box are properly grounded. Do not rely on coaxial cable shields for the ground connection.

If the cover is removed from any ANACOM product, ensure that all:

- gaskets are intact and free of damage prior to reinstallation
- mounting screws are properly installed

Ensure all connectors are waterproofed.

Power Supply

Power is obtained from the associated RF equipment. No additional power is required. Although the power feed from each transceiver is protected with a re-settable fuse, do not intentionally short the power pins. Arcing may occur.

Transceiver

Take adequate precautions to ensure the ANASAT® transceiver does not transmit a signal until it has been properly connected and set up for authorized frequencies and power levels.



Transmitter RF output power levels are adequate to cause blindness or other serious injury to body tissues. Use caution when working around the transceiver or antenna when the transmitter is active.

Power Amplifier

Be sure the transceiver TX OUT port is properly terminated prior to operation. NEVER operate the transceivers when installing or working on the TX Relay.

Ensure all the correct waveguide gaskets are used to prevent water damage not only at the transceivers, but also on all ports of the TX Relay.

TO ENSURE PROTECTION OF PERSONNEL AND EQUIPMENT, USE CARE DURING ANTENNA INSTALLATION AND WHENEVER WORKING ON OR AROUND THE SYSTEM.

LNC

Be sure the LNC units are properly terminated prior to operation. Ensure all the correct waveguide gaskets are used to prevent water damage on all ports of the RX Relay.

LNB

The use of LNBs in the Protection Switch system is very similar to the use of LNCs. The main difference is that the LNBs connect directly to the RXIF connectors on the Protection Switch Control box. Unless specifically noted, assume that any other mention of LNCs will similarly apply to LNBs as well.

Site Considerations

Peculiar installation requirements of any particular site is the responsibility of the system operator. ANACOM can engineer an optional installation

mounting kit, customized for your site and hardware. Contact ANACOM for details.

Antenna

The Protection Switch components must be attached to some form of mounting structure which is usually the antenna feed boom or the antenna mast. Specific mounting procedures will depend on the antenna used. The RF equipment is designed to be mounted on most antennas. Locate and install the antenna according to the antenna manufacturer's instructions. Specific mounting kits are available for most antennas. Contact the antenna maker or AnaCom Inc.

Lightning arrestors should be used at the site to protect personnel and equipment. Size 3/0 or 4/0 stranded copper wire should be used to bond the transceiver to the antenna frame and to the lightning protection ground rod.

Protection Switch Mounting RF Considerations

The ANASAT® PS Control box can be mounted in any position. However, for ease of use, the front panel should be in a position where the display is easily read and operated.

The length (and associated RF losses) of the interconnecting RF cables must be considered when determining the location of the transceivers and both the TX and RX relays.

The two LNCs should be mounted directly on the RX relay. The RX relay itself should be mounted directly on the RX feed of the antenna. This will minimize RF losses in the receive path and assure optimum receiver performance.

Each LNC is connected to its own transceiver with the 10 ft. (3m) coax cable provided with the transceiver. If longer cables are required, low loss coax must be used. As a rule of thumb, the LNC cable must have less than 5dB total loss at 5GHz.

(LNB and BUC only) As LNBs are independent, there will be no cable connecting the LNB and the BUC

The TX relay should be located near the two protected transceivers (or power amplifiers). This will minimize cable/waveguide cost. Over all TX loss must be considered from a system engineering view point.

Protection Switch Mounting DC Considerations

Positioning of the Control box should be within a few feet of the RX relay. Both relays require 12 volts DC to operate. The RX relay uses several amps of current when switching. Therefore, voltage drop in the relay control cable is an important consideration. The RX control cable should be as short as possible to maintain proper switching voltages. If the cable is constructed with small gauge wires, the RX relay may not switch reliably.

AnaCom recommends the distance between the RX relay and the Control box be 10 ft. (3 meters) or less and that the RX relay control cable be constructed with 18 AWG wires. If the distance must be greater, then heavier wiring must be used.

The TX relay is also a 12 VDC unit but requires less current than the RX relay. The distance between the TX relay and the Control box should be 15 ft. (5 meters) or less and the control cable should also be constructed with 18 AWG wires.

Additional voltage drop must also be considered for the cables between the transceivers and the Control box. The 12 volts used by the TX and RX relays is generated by the transceivers themselves. There is no power supply in the Protection Switch itself. Cabling between the transceivers and the Control box must assume that all power comes from only one of the transceivers. Therefore, these cables must be kept as short as practically possible. AnaCom recommends a cable length of 10 ft. (3m) or less. AnaCom further recommends that the +12 VDC wire (pin 7), and the ground wire (pin 18) both be made from 18 AWG wire or heavier.

The heavy gauge power wiring discussed in this section can be achieved by paralleling multiple smaller wires in the cable as necessary.

Physical Mounting Considerations

When mounting the transceivers and the Protection Switch components, allow enough room to adjust the antenna's azimuth and elevation. Throughout installation and during any polarization, azimuth, or elevation adjustment, ensure the cables and waveguide are not crimped or pinched.

The Control box has the same mounting holes as the AnaCom transceivers: 1/2 inch holes separated by 5 inches. Since the Control box is small and light, the box can be mounted on the very same mounts as one of the transceivers, using the same, or similar, mounting hardware.

LNC/TR Filter Mounting

A Transmit Reject (T/R) filter, the two LNCs, and the RX relay are shown in Figure 2-1. Bolt this assembly to the antenna's feed horn at the T/R filter open end. In this way, only one T/R filter is needed.

WARNING! TX power should never be applied to the antenna without an adequate T/R filter installed to protect the LNCs.

Route the two LNC cables to the transceivers, and the RX relay control cable to the Control box.

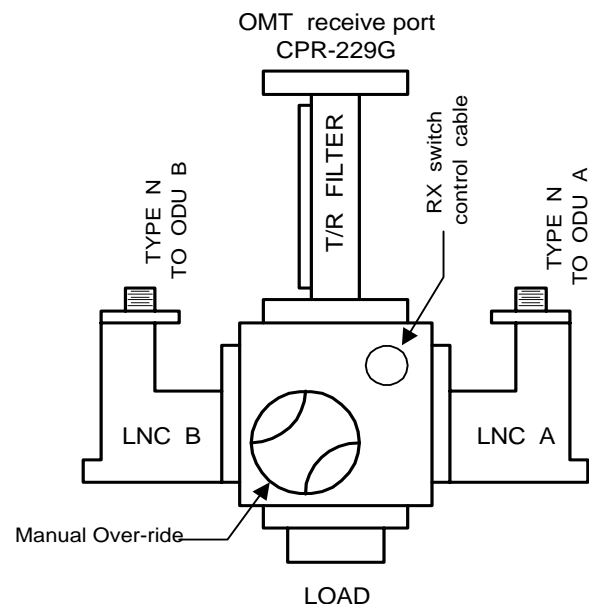

Figure 2-1 RX Switch, C band example

Cable and Waveguide Connections

Cabling Requirements

Local regulations may require that cables in occupied buildings be installed in steel conduit. Local government agencies may waive this requirement for the use of Plenum cables, which are standard cables entirely encased in solid Teflon. Check the codes in your area.

NOTE: Equipment outages due to faulty cable materials or installation are not covered by your warranty.

The cables needed for interconnecting the ANASAT®- Protection Switch to other equipment (including other AnaCom equipment) are not necessarily included. Various external equipment and configurations are too widely varied to be able to anticipate all possibilities. Specific installations can be addressed with special AnaCom Cable Kits. Contact AnaCom for details.

1. *Transmitter Feed*

(Waveguide TX OUT) Connect a section of flexible waveguide between the TX Relay common port and the antenna OMT transmit port. Waveguide should be attached to the antenna feed per manufacturer's instructions. Use another section of waveguide to connect each of the transceiver's transmit output, (TX OUT) to the A and B ports of the TX Relay. **Ensure a gasket is fitted for each port.**

(Type N TXOUT) Connect low loss coaxial cable with type N connectors between the OMT transmit port, the TX Relay (with Type N connectors) and the transceiver's transmit output, in the same configuration as described above for waveguide. **Ensure the connections are weather-tight.**

(0dBm Transceivers) If there are no external power amplifiers in the system (they may be separately protected), then install coaxial cabling as described above for the Type N transceivers.

(0dBm Transceivers) Connect sections of low loss coaxial cable with Type N connectors between the Power Amplifier input port, and the transceiver's transmit output (TX OUT). Then use waveguide to connect between the Power Amplifier outputs, the TX waveguide relay, and the antenna TX port as described above for Waveguide TXOUT. **Ensure all connections are weather-tight.**

Connect a control cable between the TX waveguide relay (circular connector) and the Protection Switch 6 pin connector labeled TX RELAY.

2. *70 MHz Modem*

(TX side) Attach a coaxial cable with N-connectors between the Protection Switch TX IF connector (see Figure 2-3) and the modulator IF OUTPUT. **Make sure that the connections are weather-tight.**

Attach another coax cable with N connectors between transceiver "A" TX IF input connector, and the Protection Switch (Control box) connector labeled TX IF A. In a similar fashion, connect another coax cable from transceiver "B" TX IF input to the Control box at TX IF B. The internal connection inside the Control box is a resistive splitter with DC blocking.

(RX side) Attach a coaxial cable with N connectors between the Protection Switch RX IF (see Figure 1-3) and the demodulator IF INPUT. **Make sure that the connections are weather-tight.**

(If the system uses BUCs instead of transceivers, skip this step) Attach another coax cable with N connectors between transceiver "A" at the RX IF output connector, and the Protection Switch (Control box) connector labeled RX IF A. In a similar fashion, connect another coax cable from transceiver "B" RX IF connector to the Control box at RX IF B. The internal connection inside the Control box is a relay. **Make sure all IF connections are weather-tight!**

3. LNC

Attach both “A” and “B” LNCs to the RX waveguide relay. Attach a high quality T/R filter to the RX waveguide relay common port. See figure 2-1. Bolt this entire assembly to the antenna RX feed point. **Make sure all ports have waveguide gaskets installed!**

Attach the RF cable supplied with the transceivers between the LNC type N connector and the transceiver connector labeled “LNC”. If a longer cable is required, insure that the replacement cable is a low loss microwave type. Make sure that the LNC attached to the “A” port of the RX relay is connected to the “A” transceiver.

Accidental cross-connection of RX cables can result in NO receive signals at the modem regardless of switch position!

Connect a control cable between the RX waveguide relay (circular connector) and the Protection Switch 6 pin connector labeled RX RELAY.

(LNB and BUC only) LNB attachment to the RX waveguide relay is the same as the above method for the LNCs

Attach the RF cables from the LNB type N connector to the corresponding RXIF connector on the Protection Switch Control box. **Make sure all IF connections are weather-tight!**

4. Terminal Connections

A data terminal or a computer with terminal software connects to the ANASAT®-Protection Switch via either RS-232 or RS-485 serial ports at the 18-pin circular connector labeled “M&C”. Appendix C shows the pin-out of the serial outputs. See chapter 5 for a discussion of serial port configurations. Optional serial computer cables are available from ANACOM.

5. Baseball switches

The connectivity of cables and Wave-Guides to the baseball switches can only be done in one possible way. See opposite tables:

| <i>TX Baseball Switch</i> | <i>Radio Transmit</i> |
|-------------------------------|---------------------------|
| Port 1 | Wave Guide to Feed |
| Port 2 | Wave Guide Radio-A |
| Port 3 | TX-Termination (large) |
| Port 4 | Wave Guide Radio-B |

| <i>RX Baseball Switch</i> | <i>Radio Receive</i> |
|-------------------------------|--------------------------|
| Port 1 | RX Feed |
| Port 2 | LNC connected to Radio-A |
| Port 3 | RX-Termination (small) |
| Port 4 | LNC connected to Radio-B |

(LNB and BUC only)

| <i>RX Baseball Switch</i> | <i>Radio Receive</i> |
|-------------------------------|--------------------------|
| Port 1 | RX Feed |
| Port 2 | LNB-A |
| Port 3 | RX-Termination (small) |
| Port 4 | LNB-B |

Final Check

Recheck all bolts and cabling. Refer to **Appendix D** to verify cable connections.

Water Resistance Wrap

The application of moisture-resistant wrap (mastic tape) to all connectors is required to prevent water entry and resultant water damage. Apply the mastic tape as follows:

1. Ensure that all connectors are tight and “O” rings are installed in plastic cable connectors.
2. Pre-cut the mastic tape or 3M type 2242 tape to the desired size. Each connector should be fitted with one piece of tape, not several short pieces.
3. Center the tape on the connector to be sealed and wrap the tape tightly around the connector. Squeeze the tape tightly and ensure that both ends of the tape have formed around the connector and the cable.
4. Apply the mastic tape to all connectors that may be exposed to moisture.

(see figure 2-2 on next page)



Figure 2-2 Example of a properly weatherized connection

Section 3. Operation

Preliminary Steps

After all of the ANACOM®-PS hardware is mounted and verified, the antenna must be aimed toward the desired satellite. Follow the antenna manufacturer’s instructions, using coordinates provided by the satellite operator.



Do not transmit until you have received authorization from the satellite network operation center, and a transmit power level from its engineering staff.

Both the on-line and the standby transceivers must be set up for the same TX frequency, RX frequency, TX gain, and RX gain values.

Refer to the AnaSat Series Transceiver Operation Manual for details.

Which transceiver is designated “A” and which is “B” is arbitrary. However, once you decide, the installation wiring, programming and operation of the system *must be consistent*.

Before applying power to either transmitter, make sure that the transmit signal path is secure

and properly terminated. Improper termination can cause severe damage to amplifier components.



Open or leaking transmission lines anywhere between the power amplifiers, the TX relay, and the antenna feed can cause personnel injury or even death.

Manual Operation

The Protection Switch operation is very simple. There are five (5) push-button switches on the front panel which are used to manually set operating conditions of the Protection Switch. See Figure 3-1.

Four red lights show active alarms from the transceivers. These lights are based on relay contact closures in the radio equipment. If separate high power amplifiers are used, their alarm relay contacts should be wired in parallel with the transceiver TX alarm relay. Then an alarm in either the power amplifier or the TX side of the transceiver will cause the red light to glow.

Four green lights show the present state of the TX and the RX relays. There should be one TX and one RX light active at any given time. If the light is flashing, this indicates the relay is in Over-Ride mode and will *not* switch if a fault occurs.

If both A and B green lights are on for either the TX or RX relay, this means the Protection Switch cannot determine the state of the physical relay. This can happen if the cable to the relay is disconnected.

One red light is used to indicate a SWITCH FAULT. This is usually caused by a faulted TX or RX relay, a cable fault, or may be due to an internal microprocessor fault.

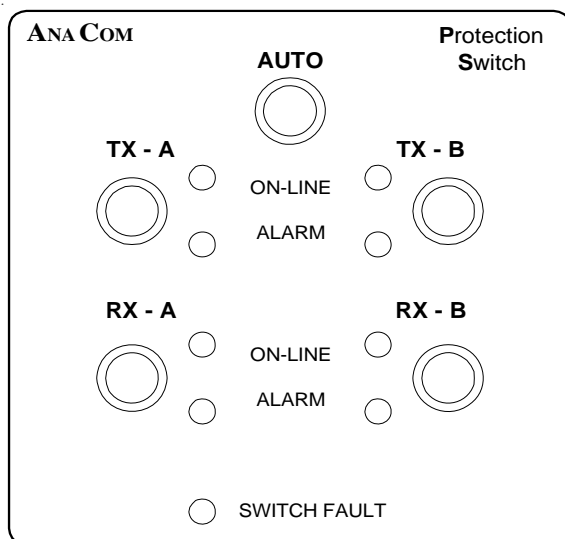

Figure 3-1 TX/RX Switch Panel Layout

AUTO Operation

By pushing the AUTO switch, the Protection Switch is put into AUTOMATIC mode for both TX and

RX. In Auto mode, the individual TX and RX relays will switch to the transceiver not having alarms.

If neither transceiver has an alarm (the normal situation), then the Protection Switch takes no action. However, should one of the on-line transceivers generate an alarm, then the Protection Switch will remove the faulted unit from service and switch the stand-by unit on-line.

AUTO mode is visually verified by noting the green ON-LINE LED is steady, not flashing.

Note that TX and RX sides of the transceiver are independent. It may be normal, for example, for the A side TX to be on -line while the B side RX is on-line.

Manual Over-ride Operation

By pushing one of the other four push button switches, the Protection Switch will force the selected equipment to go on-line.

For example, by pushing the TX A switch, the A side transmitter will be switched on-line regardless of its alarm state. The Protection Switch will keep the A transmitter on-line until the AUTO switch is pushed, or until the TX B switch is pushed.

Manual Over-ride mode is indicated by the flashing green LED on the front panel.

Note that the switch is a “non-revertive” type. This means that when a momentary alarm causes a switch action, the removal of the alarm does not cause the switch to go back to the former equipment.

If a switch is forced using one of the push-button switches, the switch will not switch back again when the AUTO button is pushed (unless there is an alarm active).

Since TX and RX switches are independent, one can be in AUTO mode while the other has an over-ride active.

M & C Operation

Terminal Display

Connect a terminal (or computer running terminal emulation software, switch.exe or Hyper terminal) to the RS-232 serial port. Set the terminal to 1200 baud, eight data bits, no parity, and one stop bit (1200,N,8,1 protocol). Refer to Appendix C for wiring diagrams for the COM ports.

The M & C terminal display gives a complete accounting of the Protection Switch alarms and status. The display is usually sent to the terminal every 30 seconds. This interval can be changed with the UTIMER command. (See Appendix A).

Figure 3-1 shows what this status screen looks like.

The top line shows the Protection Switch user label, hardware revision, and serial number.

The second line shows any alarms which may be active at the time. This includes summarized transceiver alarms in addition to actual Protection Switch alarms (see Appendix B).

The third line shows the present setting of the TX switch and if the switch is in AUTOMATIC or MANUAL over-ride mode.

The fourth line shows the present setting of the RX switch and if the switch is in AUTOMATIC or MANUAL over-ride mode.

The fifth line gives details about the serial port and how the port is presently set:

```

{USER LABEL}           AnaCom  VSAT PROTECTION SWITCH  REV:02  S/N:123456
ALARMS:  CLEAR
TX A  on line  |  TX RELAY in MANUAL MODE
RX B  on line  |  RX RELAY in AUTOMATIC MODE
DTE1: PC_MODE | UTIMER: 30.0 | TERMTYPE: TTY | ECHO on | CRLF off | BAUDRATE 19200
COMMAND>_
    
```

Figure 3-2. Remote M & C terminal screen display.

- DTE1 is the RS-232 port (DTE0 is the RS-485 port). The port operating mode can be PC-MODE if you are using an ASCII terminal, or PACKET if you are using terminal software which uses packet protocol.

- UTIMER is the screen refresh time. This can be set to any number of seconds (usually 30), or be turned OFF.

- ECHO gives the present setting for the terminal echo function. When “ON”, the serial port will echo all characters typed. When this parameter is “OFF” then the port will not echo characters.

- CRLF gives the present setting for the serial port to issue a line feed (LF) after each carriage return (CR). Options are “ON” or “OFF”.

- BAUDRATE shows the present terminal communications speed setting in bits per second (bps). Note that in order to change baudrate, *first* give the Protection Switch a command to change rate, *then* change baudrate on your terminal.

Basic M & C Commands

There are five basic Protection Switch commands. Their operation is exactly the same as pressing the front panel push-button switches.

- AUTO

This command puts the Protection Switch into AUTOMATIC mode for both TX and RX switches.

- TXA

This command switches the TX relay to the A side regardless of alarm status. This also puts the TX switch into manual over-ride mode.

- TXB

This command switches the TX relay to the B side regardless of alarm status. This also puts the TX switch into manual over-ride mode.

- RXA

This command switches the RX relay to the A side regardless of alarm status. This also puts the RX switch into manual over-ride mode.

- RXB

This command switches the RX relay to the B side regardless of alarm status. This also puts the RX switch into manual over-ride mode.

Extended M & C Commands

Several other commands are available for use in setting the serial ports or setting other user parameters. Appendix A gives a complete list of all M&C user commands.

Hand-Held Terminal

The AnaSat Hand-Held Terminal can be used to control and monitor a 1+1 Redundancy System. Please see the Section “Controlling 1+1 Redundant Systems” in the AnaSat Hand-Held Terminal Guide. A copy of this guide can be found in Appendix E.

Section 4. Theory of Operation

General

The ANASAT®-Protection Switch consists of only two major blocks:

- Switch Logic and Control
- Communications M & C

Switch Logic

The Switch Logic circuits monitor alarm relay states of both A and B transceivers, both TX and RX relays, and the five front panel push-buttons.

A latch circuit (one bit memory cell) maintains the state of each switch (TX and RX). This latch can be set or reset from several inputs:

- Front panel manual over-ride switch is pushed
- M&C computer commands
- Transceiver alarm

If the latch is set (or reset) by an over-ride action from either the push-button switches or from the M&C computer, any change of alarm state is ignored until the over-ride state is reset by the AUTO function.

Both TX and RX relays are monitored to insure they are switched to the proper side. This is accomplished by monitoring secondary switch closures in the relay itself. Should any relay NOT be in the proper position, a SWITCH ALARM is set.

The SWITCH FAULT is set whenever any of the three relays (TX, RX waveguide, and RX IF) are not in the proper position, or when any of the relays are disconnected from the Protection Switch. When the alarm is active, the front panel red light will blink, and a dry contact closure is provided at the 18 pin M&C connector. See Appendix C.

If used, LNBS are monitored by the Protection Switch Control unit via their DC current consumption.

Receive Signal Switching

Receive signals from the antenna feed through a waveguide port into the TR Filter, which prevents the transmit signal and receiver image frequencies from passing into the low noise block converter (LNC).

The T/R filter is necessary to insure that the earth station TX signals do not overload the sensitive RX low noise amplifiers, and to protect against image signals. Some antenna manufacturers include the T/R filter in their feed assembly. If not, a suitable T/R filter is available from ANACOM.

The LNC amplifies and mixes the receive signal, outputting a IF signal to the converter module.

See the Signal Flow Block Diagram in the Appendix D.

The coaxial cable connecting the LNC with the transceiver carries not only the IF signal, but also a stable LO signal from the transceiver to the LNC, plus +13 VDC power for the LNC.



*Any attempt to monitor the LO signal in the LNC cable may severely damage your test equipment due to the DC supply voltage.
Use a DC block!*

Since the LNC is not a typical TVRO device, and since it is calibrated in gain in conjunction with its own transceiver, it is not possible to use a single LNC and switch at the L band cable.

Always insure that the A side LNC is connected to the A side transceiver, and that the B side LNC is connected to the B side transceiver.

Check the serial numbers of the LNCs to see that they match their respective transceivers.

If the LNCs are inadvertently reversed, the individual transceiver gain value will not be correct, although the system may still function.

The RX alarm relay from the transceiver should be normally closed, and open only during an active alarm. This is important so that if a power failure occurs in the ODU, the alarm relay will default to the alarm state.

An active alarm input to the Protection Switch will SET the RX switch latch if the alarm is from the A ODU, and will RESET the latch if the alarm is from the B ODU.

The RX latch state drives the RX waveguide relay via high current drivers inside the Protection Switch box.

The RX latch SET and RESET will only occur if the switch is in AUTO mode. If the switch is in manual over-ride mode, any alarm input will be ignored.

A manual over-ride can be set from the front panel push-button switches, or from the M&C computer. The over-ride command will SET or RESET the latch immediately and block any alarm inputs.

The RX waveguide relay itself is a latching type relay and will not change state unless commanded to do so. Loss of power will not change its state.

Receive IF Switching

Both transceivers are always on and operational. However, only the “on-line” transceiver (ODU) is actually processing a real signal from the antenna. Since the “off-line” transceiver has its LNC terminated by the RX relay, its IF output signal will be only the LNC noise floor.

The Protection Switch contains a UHF type latching relay which is used to switch between A and B receiver outputs. Again, insure that the RX IF cabling is consistent with the RF side positioning of the LNCs on the RX relay and cabling of the LNCs to the correct transceiver.

Position confirmation contacts within the RX waveguide relay and in the RX IF relay are read by the Protection Switch logic. If the confirmation contact closures from both relays do not match the state

of the switch latch, then a Switch Alarm is set. This alarm can be seen on the front panel as a flashing red light, and the Protection Switch alarm relay is set into alarm mode. (See Appendix C)

Transmit Signal Switching

Transmit IF Signal

The TX IF signal from the modem equipment is split inside the Protection Switch and fed equally to the A and B transmitters.

This splitter is resistive and matched for 50 Ohms. If either transceiver be removed from service (physically), the TX IF connector on the Protection Switch should be terminated in 50 Ohms. The splitter gives a flat 6 dB loss of signal strength which must be accounted for in the over all earth station signal path calculations.

This splitter is not rated at C or Ku band frequencies. For SSPA protection, which requires splitting microwave frequency signals, use an external splitter.

Transmit RF Switch

There are several possibilities of transmit equipment and switching arrangements. The simplest example would be a pair of AnaSat-20EC transceivers. A more complicated example would be a pair of AnaSat-0EC transceivers working with a pair of high power amplifiers (HPAs). The HPAs may be separately protected using a second Protection Switch, or may be combined with the AnaSat-0EC as a single TX entity.

The operation of the Protection Switch is the same for any TX equipment possibility. The Protection Switch has one monitor point for the A transmitter and one monitor point for the B transmitter.

In the case of the AnaSat-20EC example, the TX summary alarm relay in the transceiver is wired to the “ODU-A M&C” connector on the Protection Switch box.

In the case of the AnaSat-0 dBm unit plus HPA, the HPA alarms must be wired to the 0 dBm unit with a separate cable. The 0 dBm unit then summarizes the HPA alarm with its’ own alarms to provide a single TX alarm for the protection switch.

The alarm relay(s) should be normally closed, and open only during an active alarm. This is important so that if a power failure occurs in the ODU, the alarm relay will default to the alarm state.

An active alarm input to the Protection Switch will SET the switch latch if the alarm is from the A ODU, and will RESET the latch if the alarm is from the B ODU.

The latch state drives the RF relay via high current drivers inside the Protection Switch box.

The latch SET and RESET will only occur if the switch is in AUTO mode. If the switch is in manual over-ride mode, any alarm input will be ignored.

A manual over-ride can be set from the front panel push-button switches, or from the M&C computer. The over-ride command will SET or RESET the latch immediately and block any alarm inputs.

The TX relay itself is a latching type relay and will not change state unless commanded to do so. Loss of power will not change its state.

Position confirmation contacts within the relay are read by the Protection Switch logic. If the confirmation contact closure does not match the state of the switch latch, then a SWITCH FAULT is set. This alarm can be seen on the front panel as a flashing red light, and the Protection Switch alarm relay is set into alarm mode. (See Appendix C)

Switch Power Control

All power for the Protection Switch comes from the AnaSat transceiver directly. The transceiver 18 pin M&C connector has a source of +13 Volts DC. This is protected from accidental shorts with a chemical fuse. This novel fuse opens when excessive current is drawn from the transceiver, but recovers automatically when the short is removed.

An internal timer, independent of the microprocessor circuit is used to insure that the TX and RX relays do not activate at the same time. Having both relays active at the same time could cause the chemical fuse to open resulting in total power loss to the Protection Switch.

Monitor and Control

The monitor and control unit (M & C), is a microprocessor-based circuit providing remote diagnostics and command capability.

Microprocessor-Based Functions

The heart of the M & C unit is the 80C188 microprocessor, operating at 8 MHz. It has 128K of SRAM and two 1MB FLASH EPROMs (electrically erasable programmable read-only memories) for program and variable storage.

The microprocessor allows long term, completely unattended remote operation of the ANASAT®-Protection Switch. All functions are accessible remotely via either of the two serial ports, which allow remote monitoring and diagnostics.

Serial Ports

Serial communication is provided through the SWITCH M&C. It is both RS-232 and RS-485 compatible.

Both ports are completely independent and allow communications rates between 300bps and 57.6kbps

Protocol is fixed at eight data bits, no parity, and one stop bit. It is set at the factory to 1200bps.

See applications examples in Section 5.

Both ports can be used with a simple “dumb terminal” or PC based terminal program such as “DT” provided by AnaCom.

Both ports can also be used in packet mode using the AnaCom packet protocol system.

Monitor Inputs

The microprocessor monitors the state of both the RX and the TX switch latches, and the SWITCH FAULT.

Control Outputs

The microprocessor controls:

- TXA over-ride
- RXA over-ride

- TXB over-ride
- RXB over-ride
- AUTO

These outputs are connected to the switch logic in parallel with the front panel push-button switches. Their activation via remote commands is exactly the same as pushing the panel switches.

Power Up and Reset functions

The microprocessor will automatically boot itself at the time of initial power application. No user action is needed.

It is highly unlikely that the microprocessor will ever hang-up. However, should it ever become necessary to re-start the processor, simply push all five front panel switches at the same time. This will initiate a re-boot of the processor. Note that this may also change the position of the TX and/or the RX relays.

Alarm Relay

A mechanical form C relay is used in the Protection Switch for external alarm indication.

The alarm relay has normally-closed contacts, so it defaults to the alarm state when power is off.

Power Distribution

All power for the Protection Switch comes from the AnaSat transceivers. Each transceiver has a source of +13 Volts DC on its 18 pin M&C connector.

Power is protected from accidental shorts with a chemical fuse. This fuse opens when excessive current is drawn from the transceiver, but recovers automatically when the current drain is removed.

The transceiver also contains a steering diode in its utility power output. The Protection Switch simply connects the A and B power sources together for its internal +12 volt supply.

The voltage is fed through another steering diode and is available on the SWITCH M&C 18 pin connector for use externally. The use of this voltage should be limited to only a few milliamps at most. Excessive current drawn from this utility output may cause the protection fuses in the transceiver to open

resulting in a total power loss of the Protection Switch. Removal of the extra load, and subsequent re-application of power to the Protection Switch may result in unwanted TX and/or RX relay switching.

The Protection Switch normally draws only a few milliamperes of current. However, the RX and TX relays draw up to 3 Amps each during a switch action. The Protection Switch circuit includes storage capacitors which can smooth out the switching current load so as not to overload the protection fuse in the transceivers. In addition, a timer circuit in the switch logic circuit is used to insure the TX and RX relays are never operated at exactly the same time.

Section 5. Serial Port Operation

The Protection Switch contains two independent serial ports for remote monitoring and control applications. Both ports are made available on the middle 18 pin weather-tight connector labeled “SWITCH M&C”.

Port 0 is a dedicated RS-485 (or RS-422) balanced interface. This port is made available as a 4 wire interface. 2 wire bus applications can be supported if the TX + is wired to RX + and TX - is wired to RX -. Port 0 should be used when ever control cable lengths are expected to be greater than 50 meters, or when multiple devices are to be connected together on a single M&C bus.

Port 1 is a dedicated RS-232 interface. Optional control pins are available if needed: DTR and DCD. These are normally used with an external modem. Simple terminal connections usually require only TXD, RXD, and GND. Port 1 should be used only when the distance to the terminal (or modem) is less than about 50 meters.

For both ports, baud rates are supported from 300 to 57,600. There is no “auto-baud” detection. However, when in terminal mode, the Protection Switch will detect a mis-match in baud rates and reset the port to 1200 baud. This is very important. Any M&C application program should first establish communications with the Protection Switch at 1200 baud, and then change baud rate to the desired speed (see Appendix A).

Assistance with controlling this unit via either (or both) serial ports is available by calling AnaCom.

Software Applications Considerations

The Protection Switch is shipped with an applications utility program called DT. This program is a “Dumb Terminal” emulator that communicates with the Protection Switch (or any AnaCom radio) with a simple ASCII exchange.

DT differs from other terminal programs in that it will automatically establish communications with the Protection Switch at 1200 baud, then change baud rate to 19,200 for faster user operation.

Any user application program should do a similar routine: First establish communications at 1200 baud by sending about 5 to 10 Carriage Returns. Regardless of how the Protection Switch port was previously configured, it will reset to 1200 baud under this condition. Next, send the desired new baudrate to the Protection Switch with the command

```
BAUDRATE 19200 (for example)
```

The Protection Switch port will immediately change to 19,200 baud. **IMPORTANT:** The user program must now be switched to the matching rate **WITHOUT** sending any characters (or the Protection Switch may fall back to 1200 baud). Communications is now established at the desired rate.

RS485/RS232 Selection

The Protection Switch does NOT require pin 12 of the 18-pin circular connector to be strapped to ground for RS-485. Both the RS-232 port and the RS-485 ports are always active.

However, AnaCom radios do sense Pin 12 for RS-485 activation. As a convenience, pin 12 is internally connected to pin 12 of both ODU-A and ODU-B connectors.

RS-232 Data Terminal Connection

Use a serial cable with a connector on one end that matches your terminal equipment (either a “dumb” terminal or a computer running terminal emulator or modem software). Connect the 18-pin weathertight circular connector to the other end, following Figure 5-1.

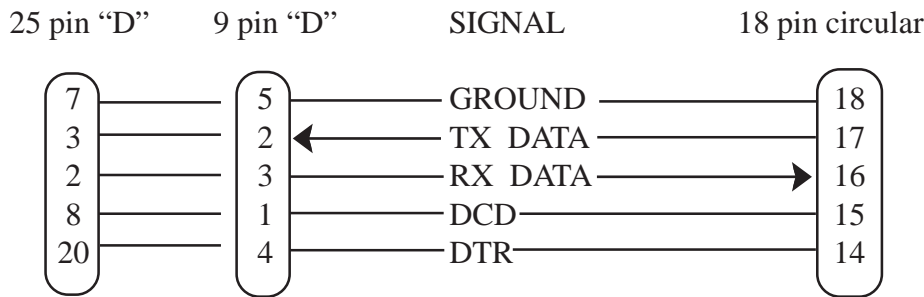

Note: Select either the 9 or 25 pin female “D” connector to match your particular data terminal. Most terminals do not need the DTR, DSR, or DCD connections.

Figure 5-1. RS232 Serial Cable Connections. Computer or terminal connections.

RS-485 Data Terminal Single Connection

RS-485 is usually utilized when the data cable needs to be longer than what RS-232 can support, or when it is required to communicate with more than one piece of equipment at a time. Always use shielded, twisted pair cable!

There are several different ways to utilize the RS-485 port. First is a simple, direct connection between the Protection Switch and the user computer terminal. In this configuration, operation of the Protection Switch is identical to that of the RS-232 connection.

Use a serial cable with a connector on one end that matches your terminal equipment (either a “dumb” terminal or a computer running terminal

emulator or modem software). Connect the 18-pin weathertight circular connector to the other end, following Figure 5-2. Note that pin 12 on the 18-pin connector should be left open.

An alternative wiring arrangement is to use a 2 wire bus. In this case, the TX + signal can be connected to the RX + signal in the connector shell. Also connect the TX - signal to the RX - signal in the connector shell as shown in Figure 5-3.

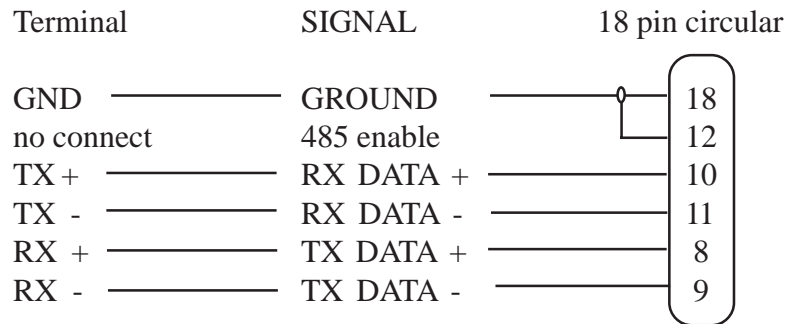

Figure 5-2. RS485 Serial Cable Connections (four wire).

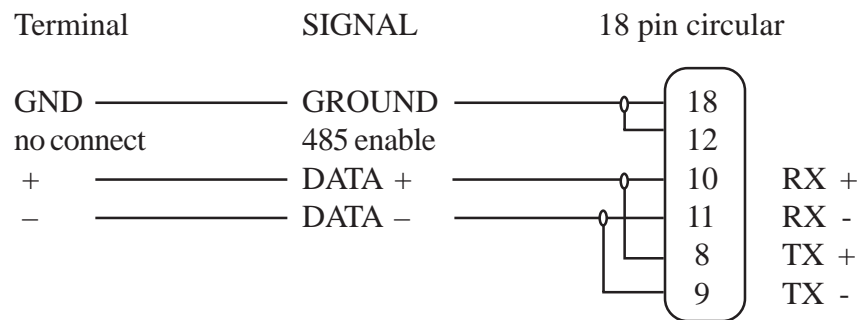

Figure 5-3. RS485 Serial Cable Connections (two wire).

Although not shown in the figures, a 120 Ohm resistor should be wired across the + to - connection at each end of the cable on both data wire pairs.

In the two wire case, a resistor should be added to each end of the data pair.

RS-485 Data Terminal: Multiple Connections

RS-485 can be used to control / monitor several different devices using one common data bus. Wiring for multiple devices is a simple extension of the single connection wiring shown above.

With multiple connections, the data cable is daisy-chained to as many devices as desired. Devices can be separated by considerable distances.

However, the maximum length of the data cable should be kept to less than 500 meters.

IMPORTANT: Any multiple connection system will *ONLY* work in data packet mode.

The ASCII interface normally associated with RS-232 operation does NOT work with RS-485 multiple connections. Therefore, a simple dumb terminal (or computer running DT or Procomm) will not work either. Multiple connection RS-485 MUST use the packet protocol defined in Packet.txt.

AnaCom radios, as well as the Protection Switch unit normally have the RS-485 port in “packet mode” at power turn on. The port is automatically switched to Terminal Mode (non-packet ASCII) when several Carriage Returns are received. The port will also automatically switch to “packet mode” when a packet containing the STX character (ASCII 02) is received.

Wiring for multi-connection RS485 is similar to Figures 5-2 and 5-3 except that the wiring is chained from one device to the next until all devices are connected. Both four wire and two wire cables are

supported by the Protection Switch. When wiring the cable, insure that the cable is one continuous line and does not have “stub” lines in the middle. This could cause reflections and unreliable operation.

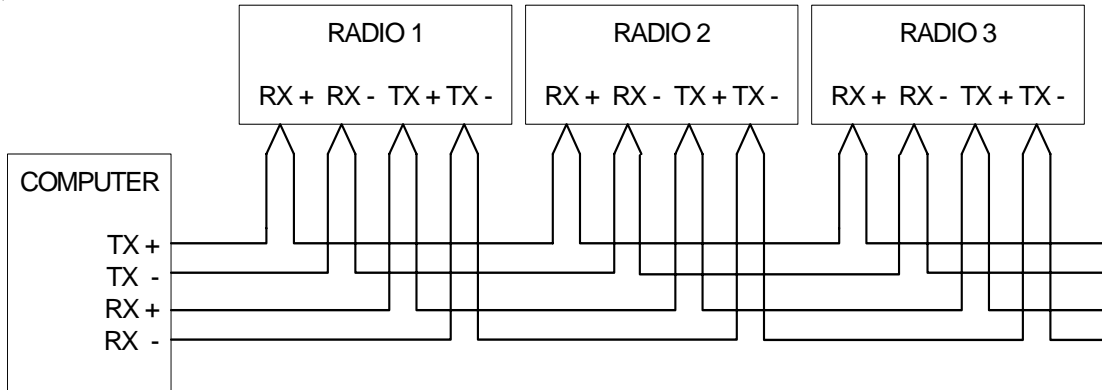

Figure 5-4 RS-485 wiring between a host computer and various devices

RS-485 Data Terminal: Translator

AnaCom radios and the AnaCom Protection Switch have two independent serial ports. One port can be configured to run RS-485 while the other one is always RS-232. It is possible to use an AnaCom unit to convert between RS-232 and RS-485.

The specific application of using the Protection Switch as a translator is given in figure 5-5. The host computer must communicate with packets, and the Protection Switch must be set with “DIGIPEAT ON”. See Appendix A.

As with other RS-485 configurations, a 120 Ohm termination resistor should be wired to the end of each twisted pair.

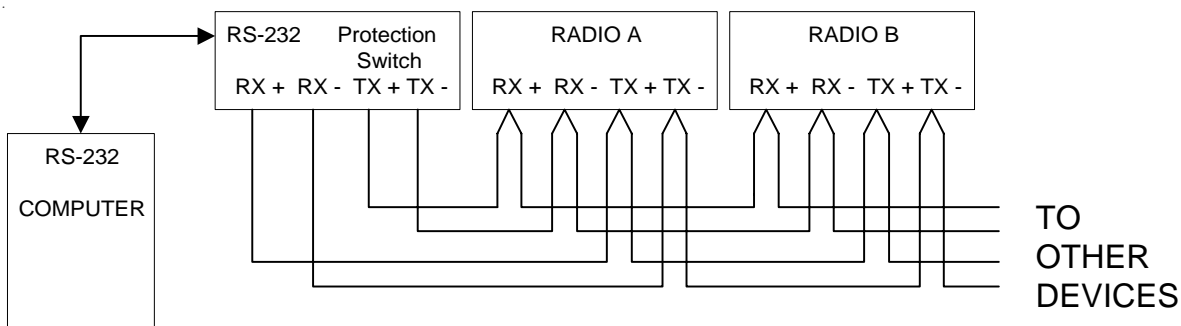

Figure 5-5 RS-485 wiring using the Protection Switch as a translator

The Protection Switch has special internal wiring which makes this translator function especially easy.

Inside the Protection Switch, the RS-485 lines are connected directly to the ODU-A and to the ODU-B RS-485 lines. This allows both transceivers and the Protection Switch unit to be automatically wired in the multi-connection RS-485 mode without special daisy-chained cabling.

The three 18 pin connectors on the Protection Switch have pins 8, 9, 10, 11, and 12 internally wired across.

For standard RS-485 (figure 5-4), simply connect the radio A 18 pin connector to the switch ODU-A connector with 1-for-1 wiring. Similarly, connect the radio B 18 pin connector to the switch ODU-B connector with 1-for-1 wiring.

When using the Protection Switch as a translator, the radio-to-switch cabling must **reverse** TX and RX wiring. This is shown in Figure 5-5 and below in Figure 5-6.

Note that pin 12 **MUST** be wired to ground (pin 18) before the radios will operate in RS-485. The Protection Switch will operate in RS-485 with or without this strap.

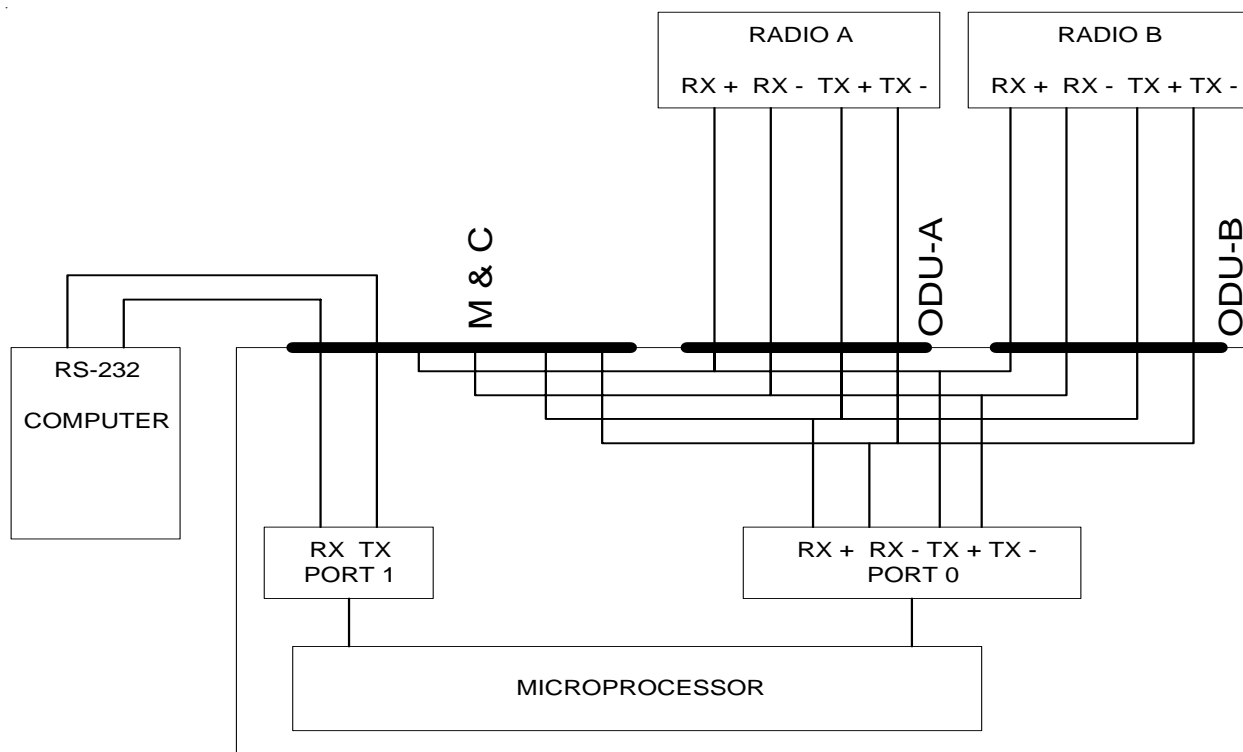
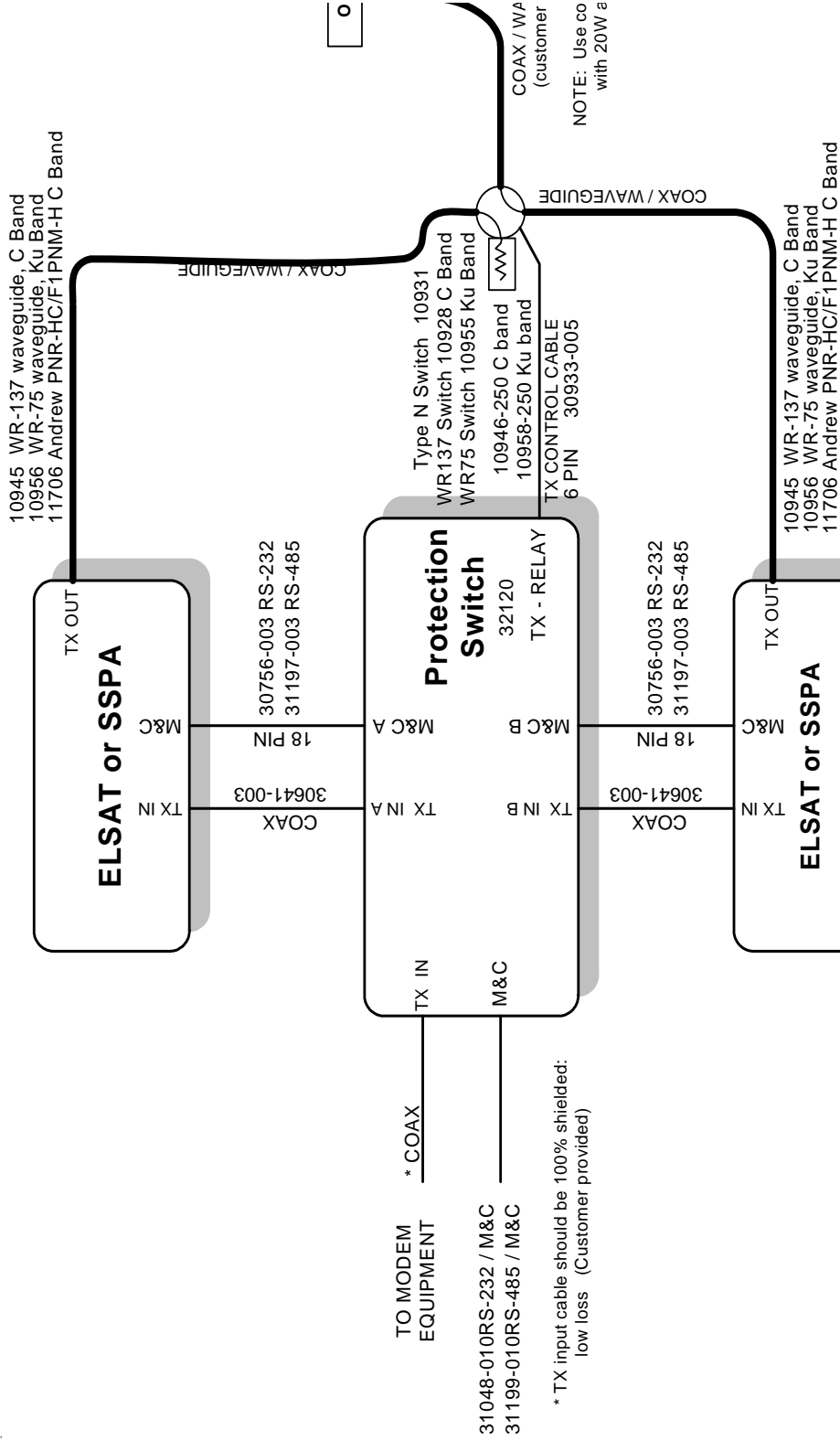

Figure 5-6 Internal Wiring of the Protection Switch



ANACOM 1 + 1 Redundancy Protection Switch Cabling Diagram
(C Band, TX only)
(Ku Band, TX only)

NOTE: Most popular configurations shown. Others are also available.

ANACOM 32123 REV01
7/30/04

Section 6. Maintenance

Built In Test Equipment

To improve and simplify maintenance routines, an external terminal (or computer) can be connected to monitor a number of critical parameters without use of additional test equipment. These include:

- Transceiver alarm status (TX, RX; A and B)
- Switch alarm and position status

Controllable Functions From The Terminal

- Force TX switch to the A or to the B side
- Force RX switch to the A or to the B side
- Restore AUTOMATIC operation

LIMITED WARRANTY

If this product should fail due to defects in materials or workmanship, AnaCom, Inc., will, at its sole option, repair or replace it with new or rebuilt parts free of charge for a period of two (2) years from the date of shipment from the AnaCom factory. This warranty covers only failures due to defects in materials and workmanship that occurs during the period of the warranty. It does not cover damage that occurs during shipment, failure caused by operation of the product outside the published electrical or environmental specifications, or malfunctions caused by misuse of the product. Expendable components are not covered under this warranty.

In order for the customer to exercise their rights to repairs under the warranty, the customer must first contact AnaCom to obtain a repair

authorization number (RMA). If it is necessary to return the product for repair, the customer is responsible for paying the cost of shipping it to AnaCom. AnaCom will pay the cost of shipping the product back to the customer when the repairs are completed. All import duties, customs fees, taxes of any kind, or any related fees are the sole responsibility of the customer.

Spare parts, repairs, or replacements are warranted to be free from defects in material or workmanship for ninety (90) days or the remainder of the limited warranty period, whichever is longer.

There are no express or implied warranties except as listed above. In no event shall AnaCom be liable for special, incidental, or consequential damages arising from the use of this product, or arising out of any breach of this warranty. All express and implied warranties, including the warranties of merchantability and fitness for a particular purpose, are limited to the applicable warranty period set forth above. No employee or representative of AnaCom is authorized to modify this warranty or AnaCom's standard warranty for any product.

Non-warranty repair service is available from AnaCom for a nominal charge. Non-warranty repair service can be obtained by contacting AnaCom and requesting a return authorization number (RMA), as described above. The customer is responsible for paying the cost of the shipping to and from AnaCom for any non-warranty repairs. Non-warranty repair service will be available for any AnaCom product for a minimum of five years from the date of its first shipment from AnaCom's factory.

Appendix A.

M & C Command Set

The Protection Switch will not respond to any command until a carriage return has been entered, terminating the command input. Multiple commands may be entered before a carriage return, using “;” as a delimiter. Example: TXA; RXA <cr> will set the transmit switch to A, and the receive switch to A.

If a command is not recognized, an error message is returned. For example, if “foo <cr>” is entered, the following is returned:

```
??????? foo
```

Alphabetical Listing of M & C Commands

| <u>Command</u> | <u>Page</u> |
|-----------------------|-------------|
| ALARMS | A-2 |
| AUTO | A-2 |
| BAUDRATE | A-2 |
| CLEAR_PASSWORD | A-2 |
| CLS | A-2 |
| CRLF | A-2 |
| DIGIPEAT | A-2 |
| DTE | A-3 |
| ECHO | A-3 |
| HELP | A-3 |
| LABEL | A-3 |
| LOCK PASSWORD | A-3 |
| MODE | A-3 |
| MODEM_MODE | A-3 |
| MODEM_STRING | A-4 |
| PC_MODE | A-4 |
| RESET | A-4 |
| RXA | A-4 |
| RXB | A-4 |
| SAVE | A-4 |
| SET_PASSWORD | A-4 |
| STANDBY_MODE | A-4 |
| TERMTYPE | A-5 |
| TXA | A-5 |
| TXB | A-5 |
| UNLOCK PASSWORD | A-5 |
| UTIMER | A-5 |

ANASAT®-Protection Switch M & C Commands

ALARMS

This command returns a list of raised alarms for the Protection Switch. The possible alarms are: RXA, RXB, TXA, TXB, SWITCH, and PROMERR.

If there are no alarms then “ALARMS CLEAR” is returned. Status of all individual alarms is evaluated ten times a second.

ALARMS

| | |
|---------|---|
| RXA | raised when the receive section of transceiver A gives an alarm. |
| RXB | raised when the receive section of transceiver B gives an alarm. |
| TXA | raised when the transmit section of transceiver A gives an alarm. |
| TXB | raised when the transmit section of transceiver B gives an alarm. |
| SWITCH | raised when either the TX or RX waveguide relay confirmation does not match the desired switch state. |
| PROMERR | raised if a write or erase operation in the PROM fails. |

AUTO

This command sets the Protection Switch into AUTOMATIC mode. The Protection Switch is free to switch both TX and RX waveguide relays based on the alarm state of transceiver A and transceiver B.

BAUDRATE [300 | 1200 | 2400 | 4800 | 9600 | 19200 | 38400 | 57600]

This command sets the baudrate of the serial channel the user is presently connected to. The serial port has been programmed for 8 bits, no parity and 1 stop bit. These parameters are not changeable.

CLEAR_PASSWORD [PASSWORD]

This command will clear an existing password. Note that the password must be given in order for it to be cleared.

CLS

In terminal mode, 25 line feeds are sent to the terminal, effectively clearing the screen.

CRLF [ON | OFF]

This command is only relevant to dumb-terminal mode. It sets (or returns) carriage-return/line-feed status. “CRLF ON” will command the M & C computer to insert a line-feed in display output following a carriage return. This can be necessary to make some terminal displays operate properly. In other cases this would be redundant.

DIGIPEAT [ON | OFF]

In packet mode, packets received on one port are transmitted out of the other port. In this manner, the Protection Switch acts as a bi-directional digital repeater.

DTE [0 | 1] (COMMAND) (ARGUMENT)

This command gets [sets] specific parameters for a specific serial port. If the command is left out, all port settings are returned. Port 0 is RS-485 and port 1 is RS-232. This command can be given from either port. Acceptable commands include: ECHO, CRLF, BAUDRATE, TERMTYPE, PACKET_MODE, TERMINAL_MODE, UTIMER.

ECHO [ON | OFF]

This command is only relevant in dumb-terminal mode. It sets (or returns) character echo mode. For example, if the operator is running a terminal emulation program on his PC with local echo disabled, type

ECHO ON

to enable echo back from the M & C computer. If the terminal is displaying doubled up characters, use ECHO OFF.

HELP

?

H

This command displays a menu of available commands for quick reference.

LABEL [TEXT]

This command erases or [sets] an alphanumeric string up to 32 characters long that the user can use to “title” or describe the purpose of the given device. This label appears on every status screen.

LOCK PASSWORD

With this command most M & C functions will be locked and further user access will be denied until the UNLOCK command is given. Those commands which remain user accessible are: UNLOCK, CLS, and ALARMS.

If a password has been established with the SET_PASSWORD command then that password must be used with the LOCK command. If there is no established password (if CLEAR_PASSWORD has been used, for instance), then M & C functions will be locked; but they can be unlocked without a password. There is only one solution to the problem of having a locked unit and/or a forgotten password:

If the unit is attached to a modem, and presently accessible remotely,
telephone ANACOM.

MODE

This command returns either MODEM_MODE or PC_MODE. Example: MODE might return MODE MODEM_MODE when the user is connected to the unit via a phone line and a Hayes compatible modem.

MODEM_MODE

This command is used to tell the M & C computer that a Hayes compatible modem is attached (or is about to be attached) to the serial port. The way this would be used is a user would enter this command from a PC using a null modem cable, then disconnect the PC and attach a modem directly to the port via a modem cable. RX, TX, DCD and signal GND lines must be properly connected.

Once MODEM_MODE is activated, the M & C computer will no longer display dumb terminal display updates or generate packets in packet mode until the DATA-CARRIER_DETECT line becomes active, indicating the modem is off-hook and connected to another modem.

MODEM_STRING [TEXT]

When the M & C computer is in modem mode it will periodically send a Hayes compatible initialization string of up to 40 characters to the modem to make sure it is properly configured. The user can get [set] this string via this command. The default string as part of factory settings is:

```
MODEM_STRING AT S0=1 &C1 &S0 \Q0 E0
```

PC_MODE

This is the converse of MODEM_MODE. At any time, the user may type PC_MODE and the M & C computer will again behave as if a PC or network is directly attached to the serial port rather than a modem.

RESET

This command resets the M & C computer. This should not normally cause the Protection Switch to change state.

RXA

This command forces the RX switch to the A side and into MANUAL mode. The RX switch will remain on the A side regardless of any RX alarms. Use the AUTO command to revert the RX switch to automatic operation.

RXB

This command forces the RX switch to the B side and into MANUAL mode. The RX switch will remain on the B side regardless of any RX alarms. Use the AUTO command to revert the RX switch to automatic operation.

SAVE

This command saves present M & C operating parameters to a FLASH EEPROM. Note that the Protection Switch state of RX and TX relays is NOT saved. This is only used to store serial port operating parameters.

SET_PASSWORD [PASSWORD] [PASSWORD]

The M & C computer supports password control of M & C functions. One potential use of this feature would be for leaving the Protection Switch unit connected to a modem on an open telephone line. A valid password must be an alphanumeric string with no imbedded blanks, and between four and eight characters long inclusive. It must be given twice to ensure accuracy.

An existing password must first be cleared before setting a new password. This is done with the CLEAR_PASSWORD command.

STANDBY_MODE [HOT | WARM]

Conventionally, when a protection system has been set up, the unit in standby mode is in a HOT standby mode. This means that the TX function is ON and the standby unit is transmitting into a load through a baseball switch. Beginning with REV 11 of the protection switch firmware, and REV 48 of the ODU firmware, this command can be used to select a WARM standby mode instead. In this state, the transmitter will be muted and will not be transmitting while in standby mode. The positive aspect of this feature is that the system will draw only half the current, since the TX function in the standby ODU will be muted. The negative aspect is that the transmit function in the standby unit will not be monitored for alarms until it is brought back online.

Entering this command without an argument will return its present state. Use the SAVE command to make the setting permanent.

Note: unplugging the control cable that runs from the protection switch to the ODU will remove the mute control line being asserted by the protection switch, and the ODU will return to full output power!

TERMTYPE [TTY | VT52 | VT100] (OLD UNITS, OBSOLETE)

This command is only relevant to dumb-terminal mode. It sets (or returns) the terminal emulation mode.

TTY Terminal Mode: this is a basic 80 character by 25 line ASCII “dumb” terminal mode.

VT52 Mode: This is a standard terminal emulation, more intelligent than TTY.

VT100 Mode: This is an enhanced communications terminal emulator with a fixed display window.

There are some control characters that will be filtered by the terminal driver when the M & C computer is in terminal mode. These control characters will be ignored in packet mode.

CTRL-E: This will erase the screen, similar to the CLS command.

CTRL-Q: refer to the description of CTRL-S.

CTRL-S: Periodic screen updates will be squelched until the user has finished entering present command or hits CTRL-Q.

CTRL-BS: (Backspace) The present input command will be erased.

TXA

This command forces the TX switch to the A side and into MANUAL mode. The TX switch will remain on the A side regardless of any TX alarms. Use the AUTO command to revert the TX switch to automatic operation.

This command forces the TX switch to the A side and into MANUAL mode. The TX switch will remain on the A side regardless of any TX alarms. Use the AUTO command to revert the TX switch to automatic operation.

TXB

This command forces the TX switch to the B side and into MANUAL mode. The TX switch will remain on the B side regardless of any TX alarms. Use the AUTO command to revert the TX switch to automatic operation.

UNLOCK PASSWORD

This command will unlock M & C functions for user access.

UTIMER [NUMBER]

This command is only relevant to dumb-terminal mode. It sets (or returns) the number of seconds between automatic display updates. Note that changing baud rate will automatically revert to a default appropriate for that particular baudrate.

Appendix B. Alarm List

The ANASAT-C Protection Switch provides a simple control and monitor feature. If an abnormal condition occurs, a description of the abnormality is sent via the M & C serial port to the operator's console.

Transceiver alarms are monitored and related via the serial port even though they are not Protection Switch alarms per se. This is done so that a single point remote M&C computer can see transceiver summary alarms *as alarms* even though only the Protection Switch unit is actually connected.

A true Protection Switch alarm is reported as simply a SWITCH alarm. This almost always means that one of the waveguide relays has not switched to the proper side. It could also mean that the internal RX IF relay has not switched properly.

| ALARMS | |
|---------|--|
| TXA | there is a summary TX fault on the A transceiver |
| TXB | there is a summary TX fault on the B transceiver |
| RXA | there is a summary RX fault on the A transceiver |
| RXB | there is a summary RX fault on the B transceiver |
| PROMERR | the M & C PROM checksum fails |
| SWITCH | one of the waveguide relays or the RX IF relay has not switched properly |

Appendix C. Connector Wiring

6-Pin Circular Weathertight Connectors

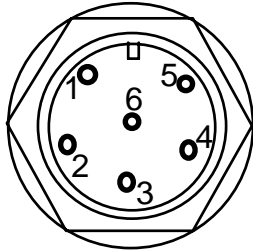
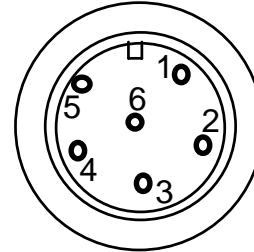
Cable Wire View

Cable End View

| Pin | Signal | Description |
|-----|--------|---------------------|
| 1 | P12V | + 12 VDC |
| 2 | A | A side relay coil |
| 3 | B | B side relay coil |
| 4 | ACON | A side confirmation |
| 5 | GND | Ground |
| 6 | BCON | B side confirmation |

Note dimple next to pin 1

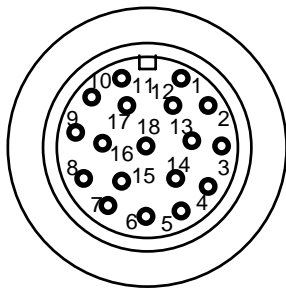
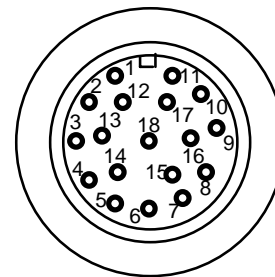
18-Pin Circular Weathertight Connector: M&C



Cable End View

Cable Wire View

| Pin | Signal | Description | Pin | Signal | Description |
|-----|--------|----------------------------|-----|--------|-----------------------------|
| 1 | RYNO | Alarm Normally Open | 10 | RX+ | Differential Receive Data |
| 2 | RYNC | Alarm Normally Closed | 11 | RX- | Differential Receive Data |
| 3 | RYC | Alarm Common | 12 | RS485 | RS485 Jumper (open for 232) |
| 4 | n/c | | 13 | TXM | TX Mute* |
| 5 | n/c | | 14 | DTR | Data Terminal Ready |
| 6 | n/c | | 15 | DCD | Data Carrier Detect |
| 7 | P12V | +12V DC Power | 16 | RXD | Receive Data RS232 |
| 8 | TX+ | Differential Transmit Data | 17 | TXD | Transmit Data RS232 |
| 9 | TX- | Differential Transmit Data | 18 | GND | Ground |

Note dimple next to pin 1.

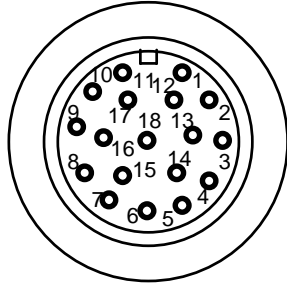
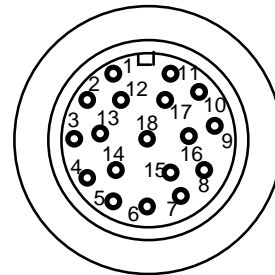
(*) active with short to ground.

18-Pin Circular Weathertight Connector: ODU-A and ODU-B



Cable End View

Cable Wire View

| Pin | Signal | Description | Pin | Signal | Description |
|-----|--------|--------------------------|-----|--------|-----------------------------|
| 1 | RY1NC | RX Alarm Normally Closed | 10 | RX+ | RS-485 Receive Data |
| 2 | n/c | | 11 | RX- | RS-485 Receive Data |
| 3 | RY1C | RX Alarm Common | 12 | RS485 | RS485 Jumper (open for 232) |
| 4 | n/c | | 13 | TXM | TX Mute* |
| 5 | RY2NC | TX Alarm Normally Closed | 14 | DTR | Data Terminal Ready |
| 6 | RY2C | TX Alarm Common | 15 | DCD | Data Carrier Detect |
| 7 | P13V | +13 Volts DC Power | 16 | RXD | Receive Data RS232 |
| 8 | TX + | RS-485 Transmit Data | 17 | TXD | Transmit Data RS232 |
| 9 | TX - | RS-485 Transmit Data | 18 | GND | Ground |

Note dimple next to pin 1

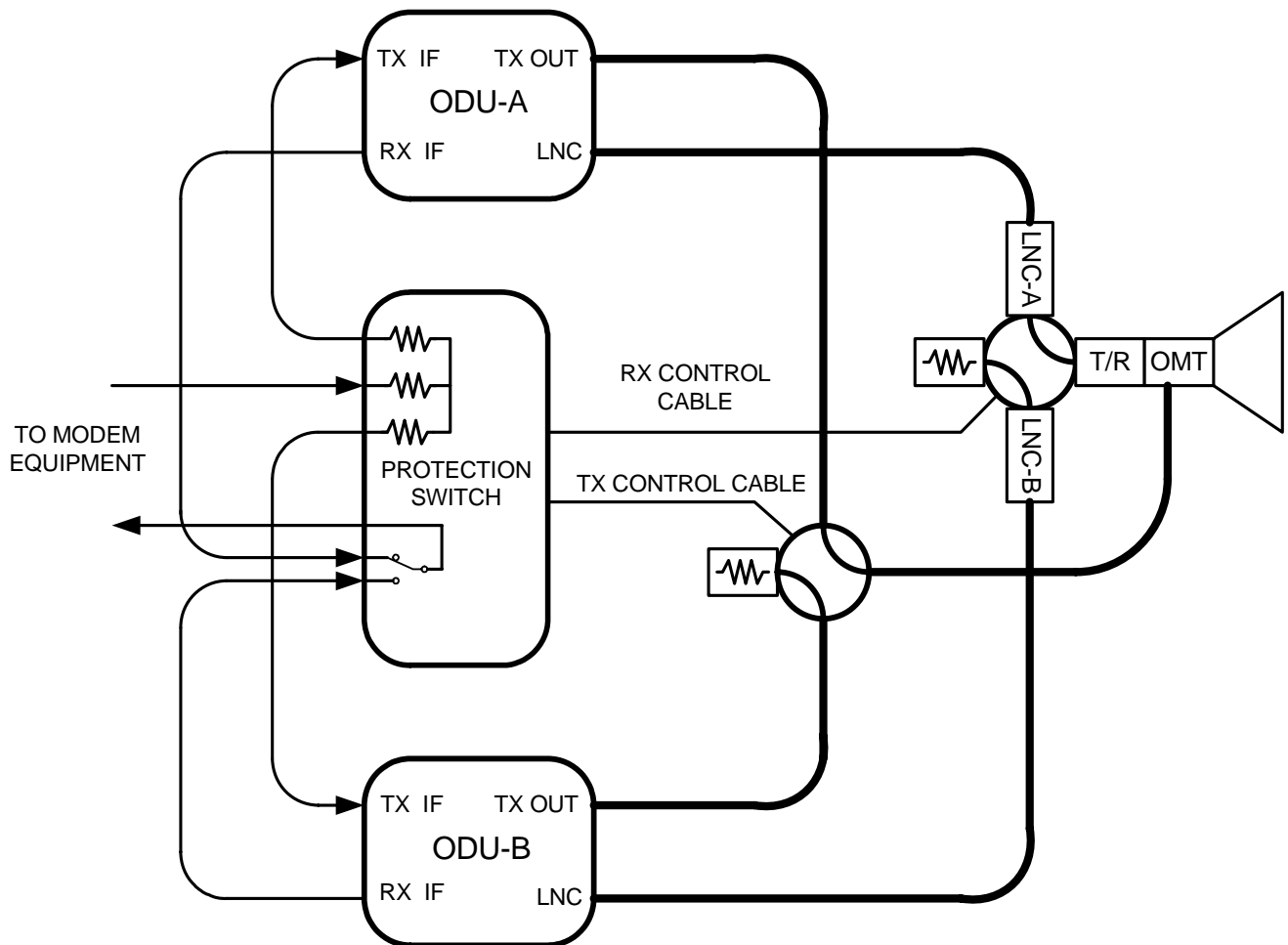
* active with short to ground

Appendix D. Drawings and Diagrams



ANASAT®-PS Simplified Signal Flow Block Diagram

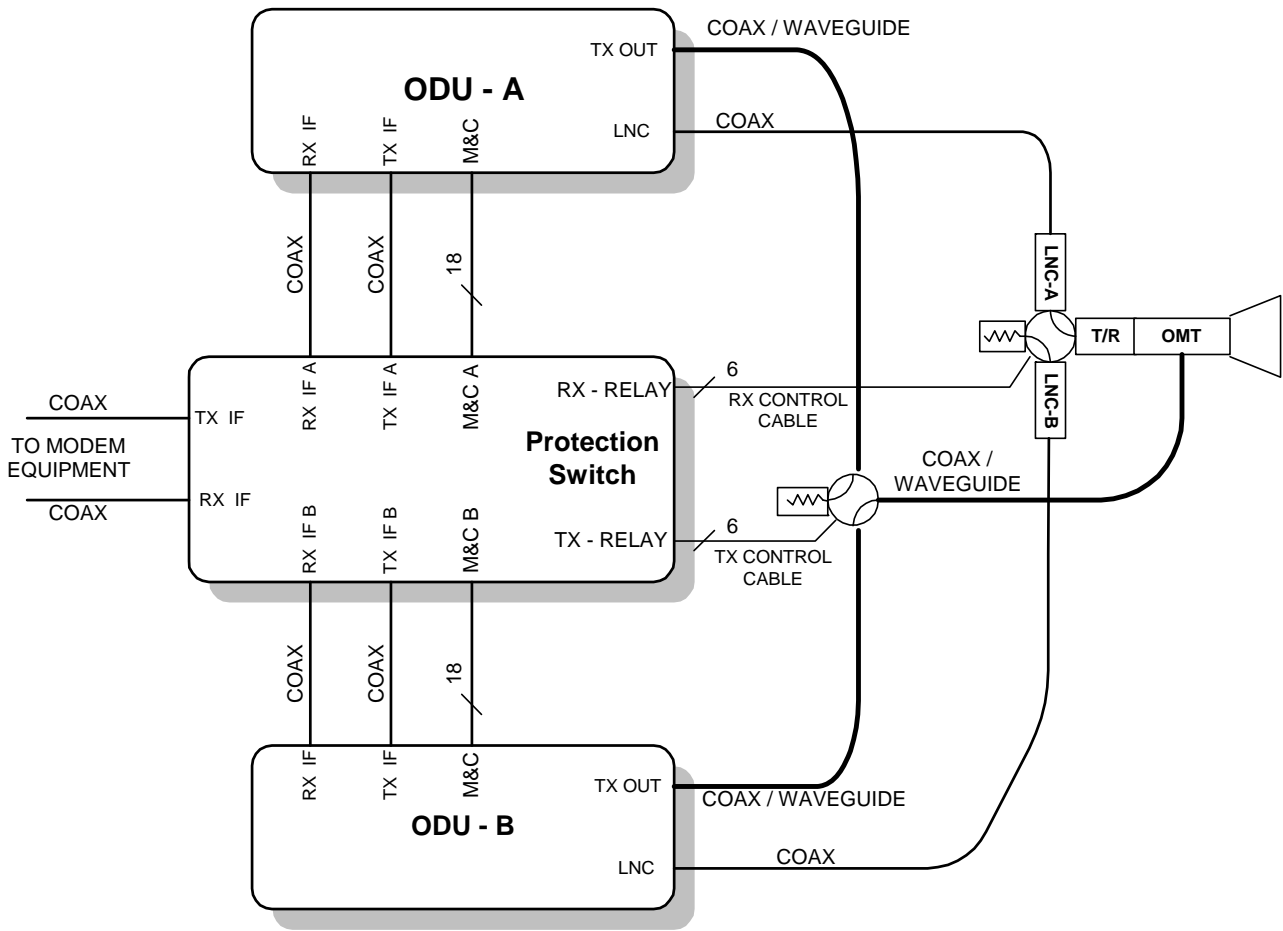

ANASAT®-PS Cabling Interconnection Diagram.

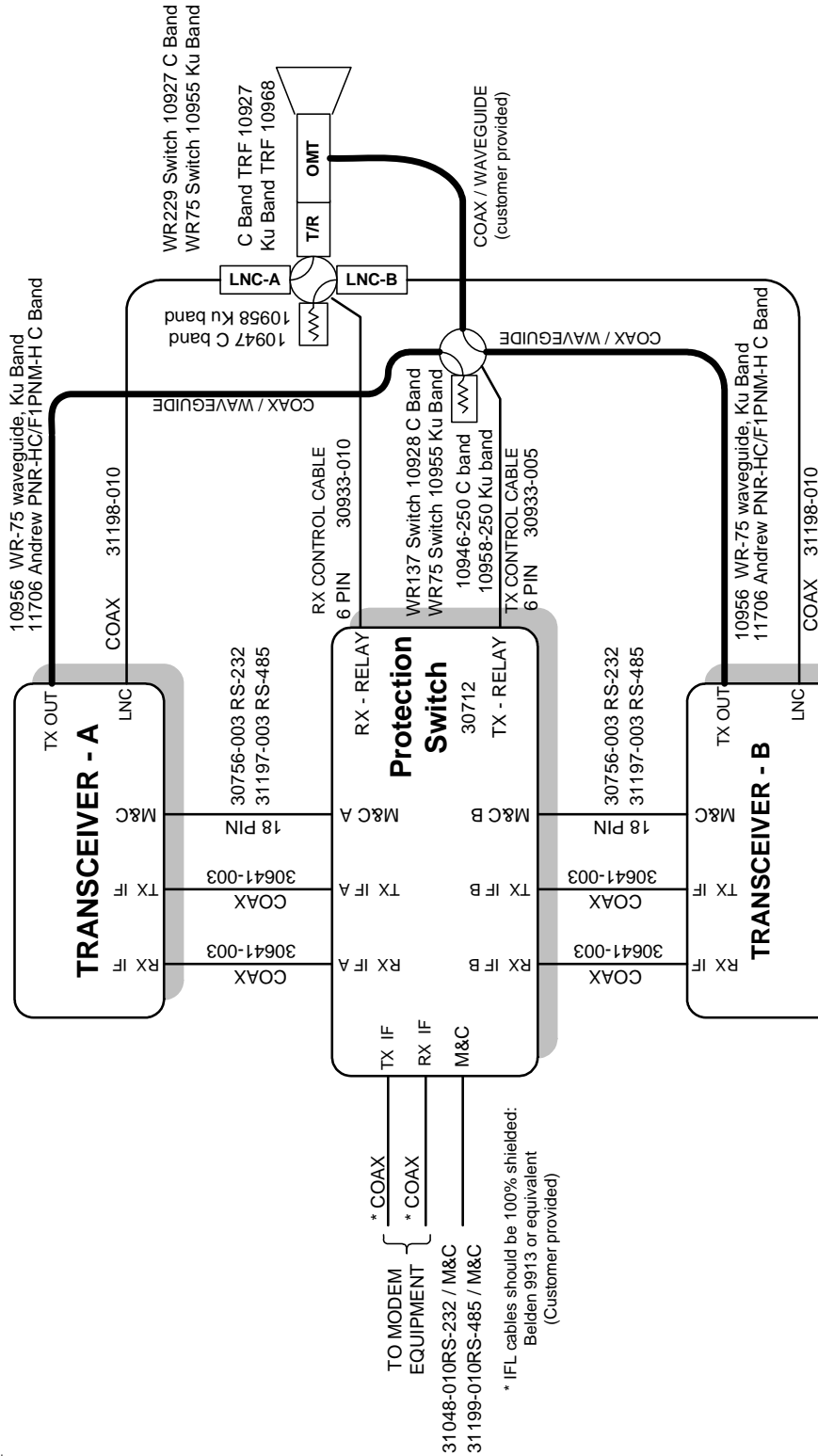

ANACOM 1 + 1 Redundancy Protection Switch Cabling Diagram
(C Band, Single Enclosure)
(Ku Band, Single Enclosure)

ANACOM 30908 REV05
4/13/04

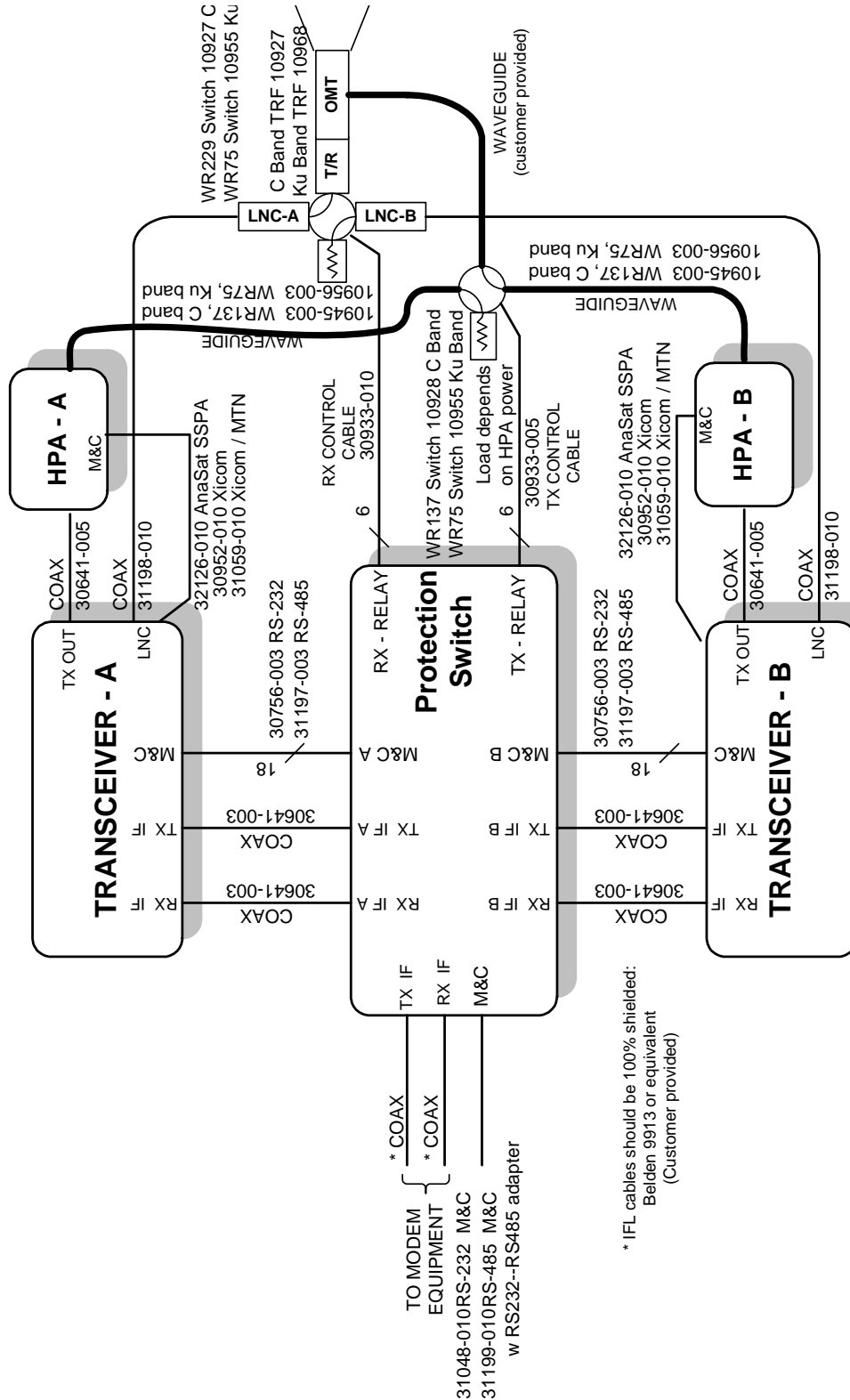

ANACOM 1 + 1 Redundancy Protection Switch Cabling Diagram (External HPA)

ANACOM 3090904 6/6/2004

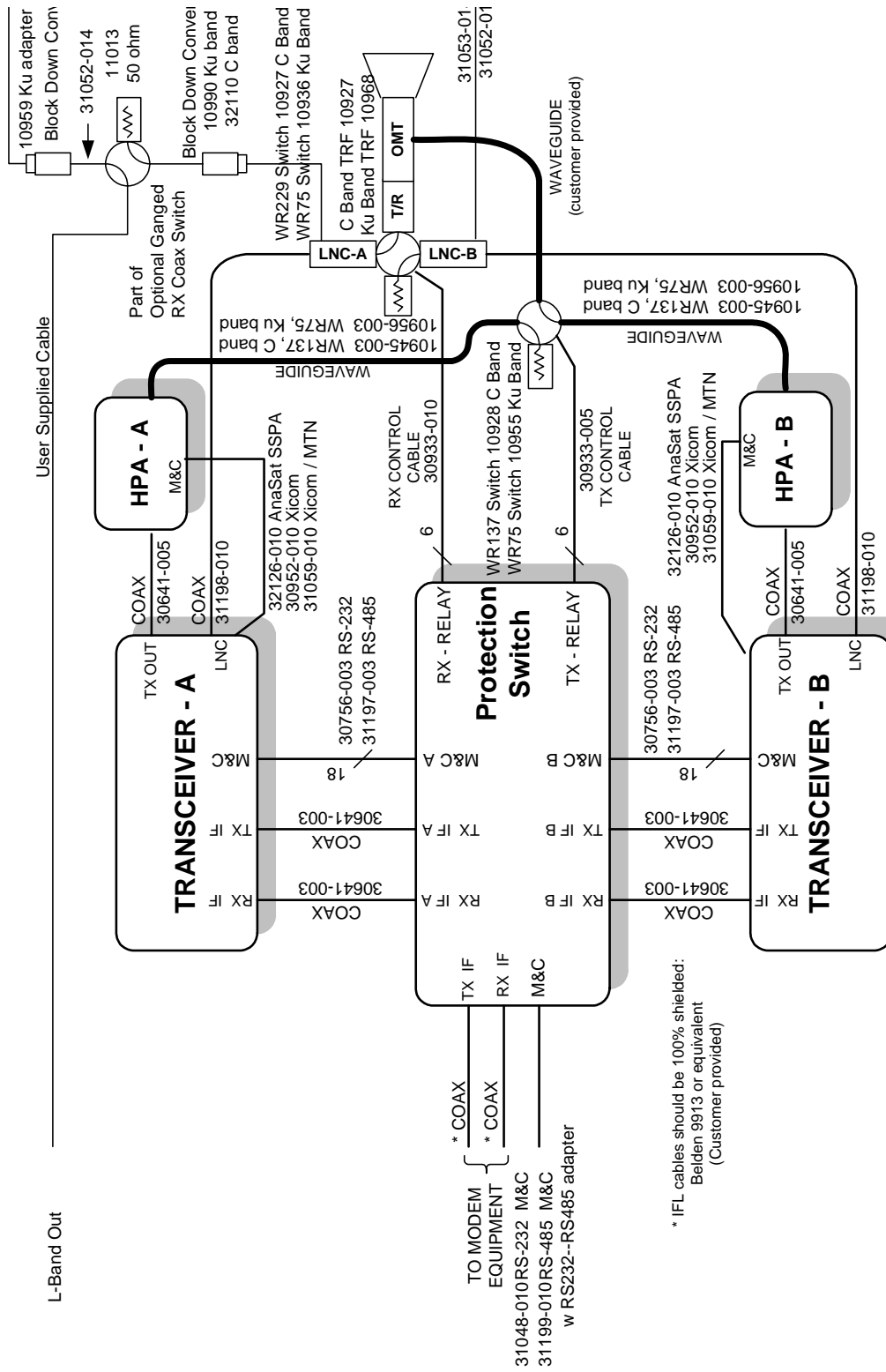

**ANACOM 1 + 1 Redundancy Protection Switch Cabling Diagram
(External HPA and Ganged RX Switch)**

ANACOM 3090904 6/6/2004

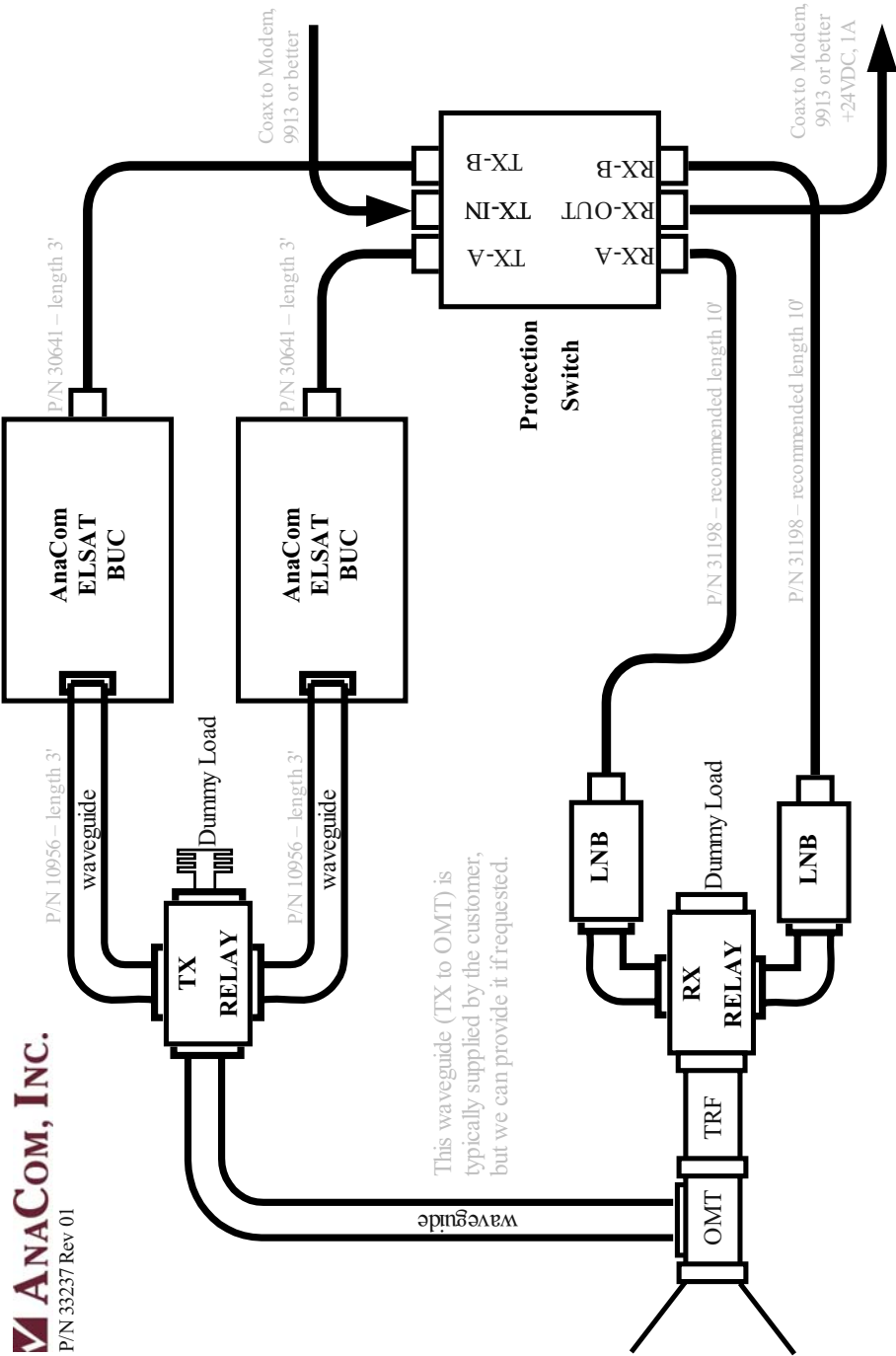

1+1 Redundant Protection Switch for two ELSAT BUCs and LNB protection.
This diagram shows RF/IF connections only, the control cables (PS to BUCs & PX to Relays) are not shown

